

Leak Detection Systems (Water, Fuel, Chemicals)

The Problem – Water Leakage

enia

- Even a minor water leakage can cause major problems if not sensed and located in time.
- The water leakage may come from:
 - Water pipes
 - Effluent pipes
 - Air conditioning condensates
 - Stormwater
- Conventional leak detection systems offer only POINT DETECTION and will give an alarm if water reaches a particular small area of the sensor. Water may freely flow elsewhere undetected!



The Problem - Fuel Leakage

enia

- Even a minor fuel leak can cause serious damage to the plant or the environment is not detected in time

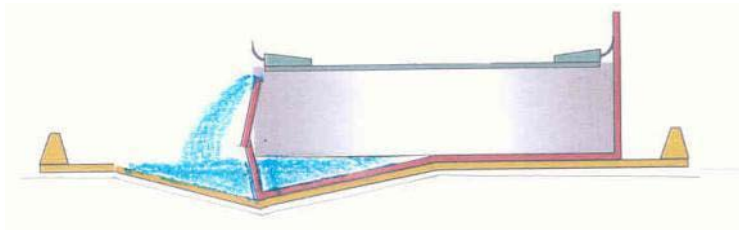

The Solution

enia

- **TraceTek[©]**
- **Leak Detection & Positioning System.**
 - *Consists of a thin plastic “cable” that can sense any drop of water (or fuel or other chemicals – depending on the type) along any point of its length.*
- **Can trace (depending of cable type)**
 - *Water*
 - *Fuel*
 - *Industrial solvents*
 - *Acid – basic fluids*

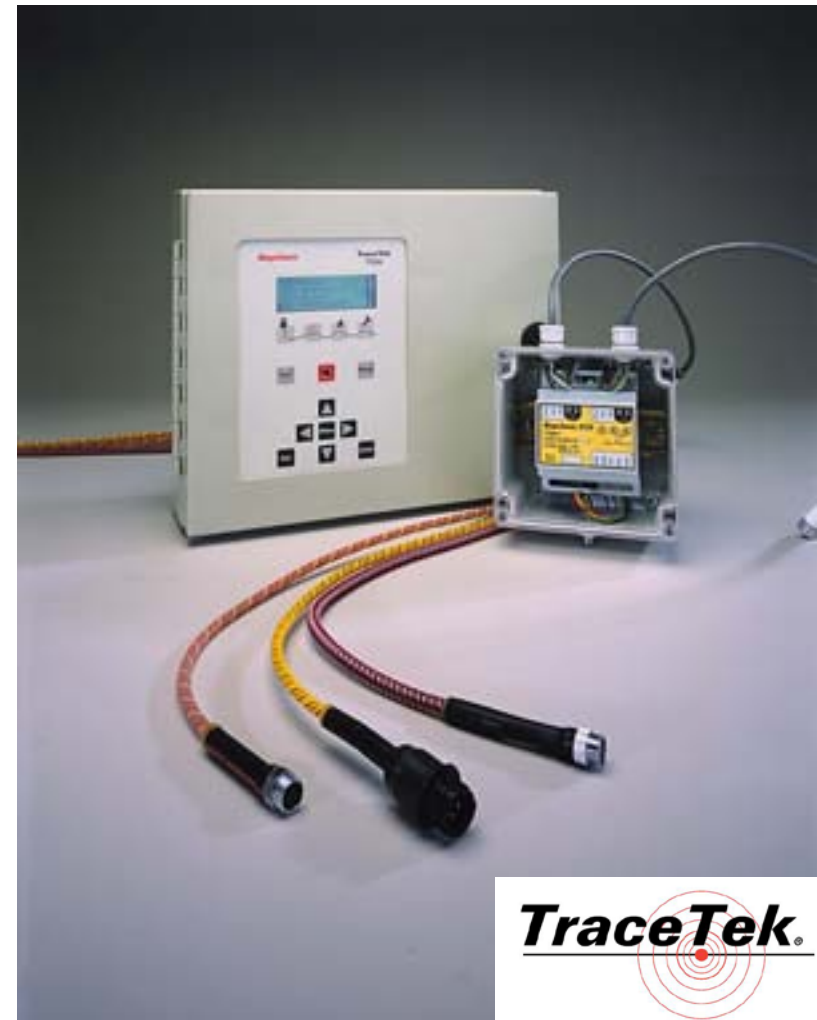

TraceTek.

Operation principle, Water sensor

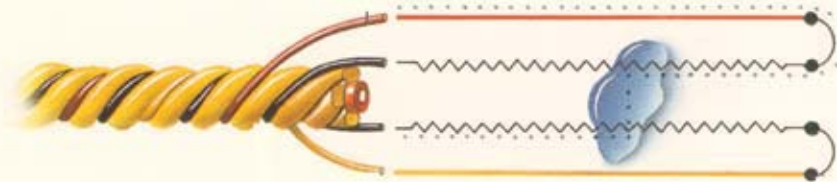

- The sensing cable is composed of four conductive polymer fibers wrapped around a polymeric core, bridged at their end.
- The sensing circuit monitors continuously the resistance of the conductive polymer circuit.
- Water will cause a short circuit between the conductive polymer fibers at the point of the leakage. The circuit resistance will be reduced.
- The sensing circuit will detect this reduction of the resistance, will give an alarm and will indicate the position of the leak based on the new measurement of the resistance of the circuit.
- After rectification of the problem and drying of the cable the system is again operational
- The system may have a “tree” configuration. With sensing cable lengths, branching (non sensing) cables, “tee” fittings etc.
- All cables and components are pre-terminated. Installation is easy (just laying down and plugging the components according to the design sheet).

TraceTek Advantages

enia

- Immediate sensing of the leak and indication of its exact position
- Highly resistant system to corrosion and environmental factors.
- After rectification of the problem the system reverts to its original “sensing” state.
- Easy installation. All components are pre-terminated. It is enough to plug, according to the design, and fix on the floor with adhesive clamps.
- Full range of components, suitable for any configuration irrespective of its complexity (sensing cables and branching cables at standard lengths, branching components, cable terminations, various control units).
- Can be linked to the central building management system



Products of

tyco | Thermal Controls

Applications - Water Leak Sensing

enia

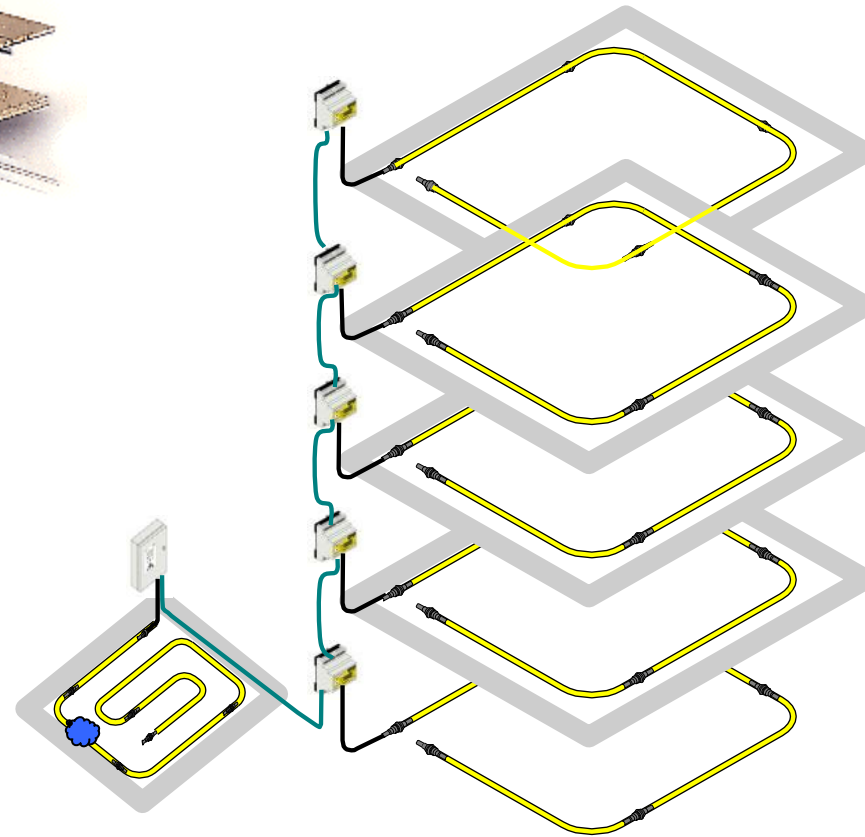
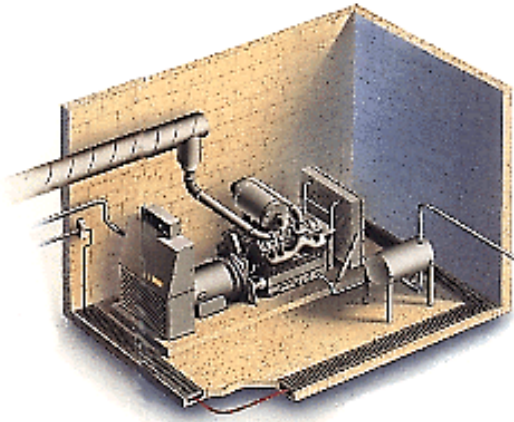
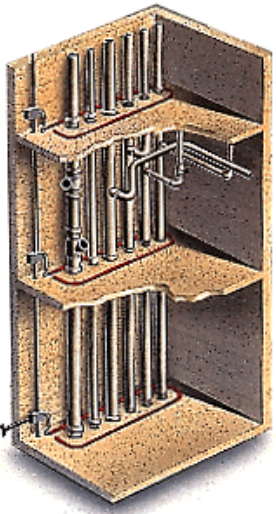
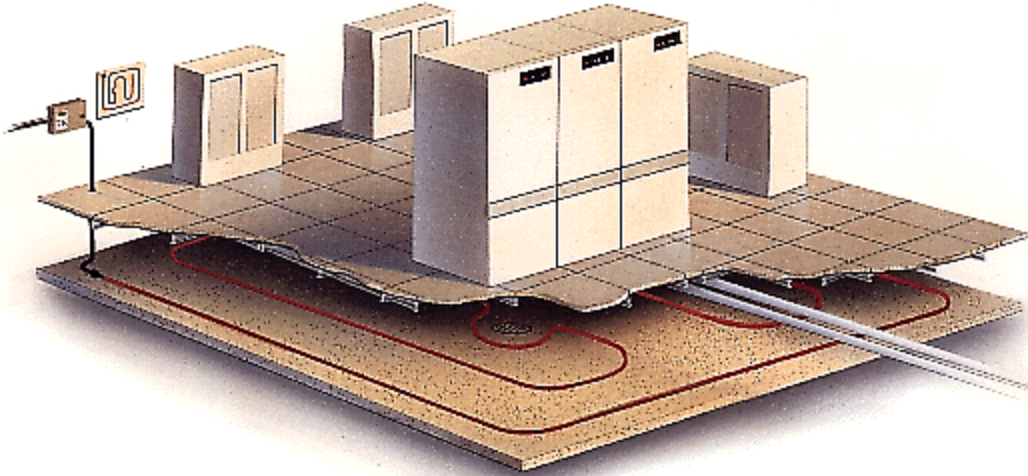

Applications - Water Leak Sensing

enia



Applications - Fuel Leak Sensing



- *Buried pipes or tanks*

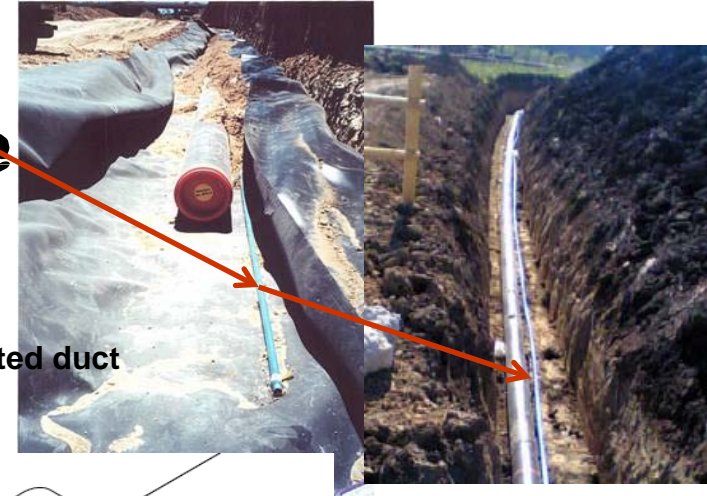
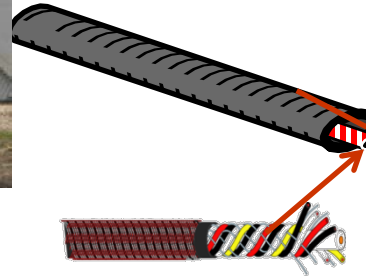
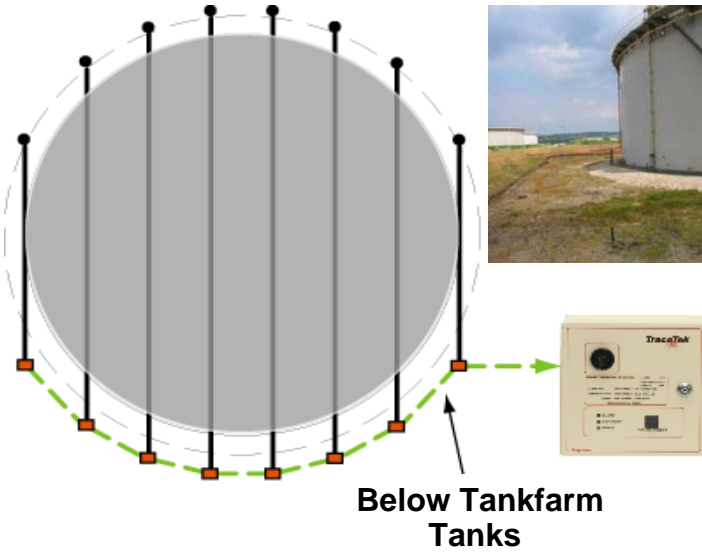

- *Below pipes*

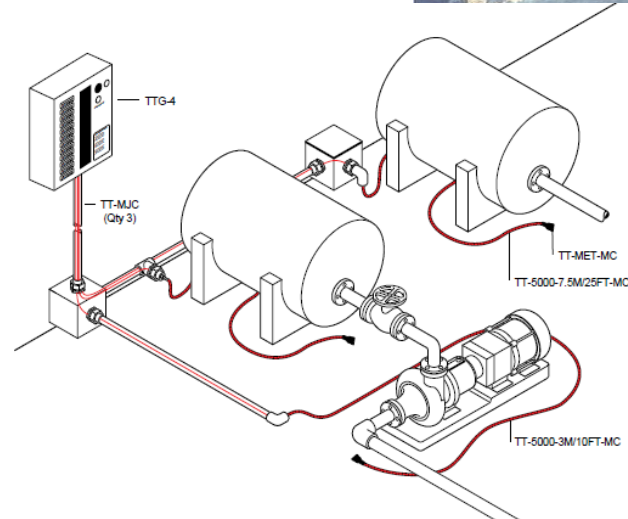

Applications - Fuel Leak Sensing

enia



- *Airfield fuel distribution system*

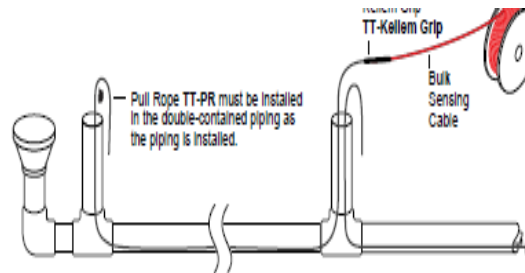
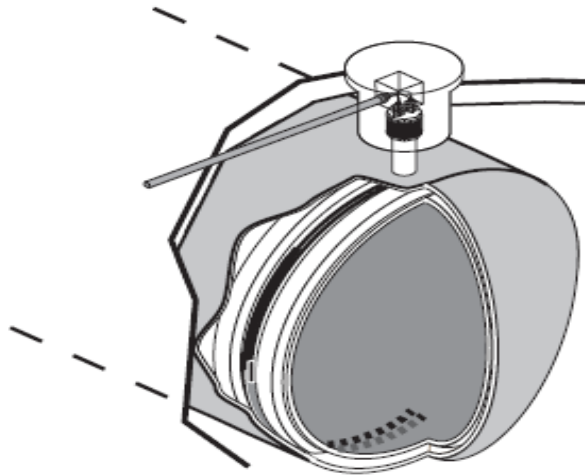

- *Double wall tanks or pipes*



- *Tankfarm stormwater ducts*

Chemicals Sensing Cables



Group	Chemical	TT3000	TT5000	TT5001	TT7000
Acid	Acetic Acid 25% / CH3CO-OH	Yes			Yes
	Acetic acid 50%-99.4% / CH3COOH	Yes			Yes
	Ferric Chloride / FeCl3	Yes			
	Hydrochloric acid 9.5-37% / HCl	Yes			Yes
	Hydrofluoric acid 49% / HF	Yes			
	Nitric acid 15-65% / HNO3	Yes			Yes
	Sulfuric acid 25-98% / H2SO4	Yes			Yes
Alcohol	Ethanol (95% in H2O) / CH3-CH2-OH	Yes		60 min	
	Ethanol 100% / CH3-CH2-OH			60 min	
	Isopropanol	Yes		90 min	
	Isopropyl Alcohol (IPA) / (CH3)2CHOH			90 min	
	Methanol (100%) / CH4O			45 min	
	Methanol (up to 95% in H2O)	Yes			
Caustic	Sodium hydroxide (concentrated) / NaOH	Yes			
	Sodium Hypochlorite / NaOCl	Yes			
	tetramethylammonium hydroxide (TMAH) / (CH3)4NOH	Yes			
Fuel	Diesel #1		60 min		
	Diesel #2		120 min		
	Fuel oil #6		*		
	gasoline		9-20 min*	48 min	
	gasoline vapor		3 days	5 days	
	Jet A		50 min	4-11 hrs	
	Jet B		Yes	Yes	
	JP-10		40 min		
	JP-4		15 min	<5 hrs	
	JP-5		70 min	<4 hrs	

Group	Chemical	TT3000	TT5000	TT5001
Fuel	JP-7		25 min	10 hrs
	kerosene		47 min	
	Light Sweet Crude		3 hrs	
Hydraulic fluid	Automotive transmission fluid		4-8 hrs	
	brake fluid (DOT 3)			~30 hrs*
	hydraulic oil		3-8 days*	
Lubricant	SAE 20 motor oil		<1 day	
	SAE 30 motor oil		2 days	
Other	Aliphatic hydrocarbon (generic)		Varies	
	Ammonium Hydroxide / NH4OH	Yes		
	anisole	Yes	1.7 hrs	33 min
	carbon disulfide			3 min
	chloroform		12 min	10 min
	dimethylformamide	Yes		2 hrs
	Dowtherm A		10 hrs	90 min
	ethyl acetate			20 min
	ethylene glycol	Yes		
	Formaldehyde			
	Formalin	Yes		
	Freon TF		22 min	42 min
	gum turpentine		10 min	20 min
	heptane		10 min	60 min
	Hydrogen Peroxide / H2O2	Yes		
	mineral spirits		20 min	
	Mobiltherm 603		<9 hrs	<4 hrs
Naptha		15 min		

Group	Chemical	TT3000	TT5000	TT5001
Other	PCB		<9 hrs	
	polyurethane (PUR)		?	?
	Prestone antifreeze	Yes		
	Shell Diala X transformer oil		13 hrs	
	styrene monomer		20 min	8 min
	tetrahydrothiophene		25 min	27 min
	Solvent	50/50 methylene chloride /methanol		
acetone				10 min
Acetone (30% in H2O)		Yes		
Acetone (50% in H2O)		Yes		80 min
butyl acetate				20 min
carbon tetrachloride			20 min	20 min
chlorobenzene			21 min	10 min
cyclohexane				32 min
dichloromethane			13 min	5 min
Ethyl benzene			Yes	
Methyl Ethyle Ketone (MEK)				10 min
Methylene Chloride				~5 min
N-methyl pyrrolodone				60 min
toluene			18 min	10 min
trichloroethane				20 min
trichloroethylene				8 min
xylene			20 min	35 min

Completely Modular System

enia



Sensing Cables



.....

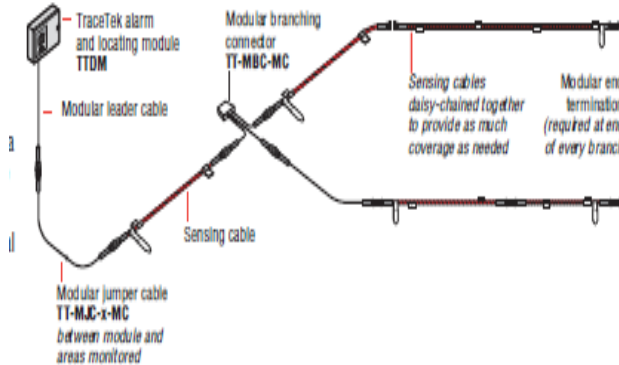

Pre-terminated components



Control units

Point sensors



*ENIA S.A. 59B Apostolopoulou Str.
GR-15231 Halandri
Athens, Greece
Tel: +30 210 6754801
Fax:+30 210 6754804
info@enia.gr
www.enia.gr*